

# Rosários 4<sup>®</sup>

279

Autumn . Winter

Gisela



DESIGN  
FILIPA CARNEIRO

[@filipa\\_nionoi](#)

AURORA



70%  
Mohair Kid



30%  
Silk

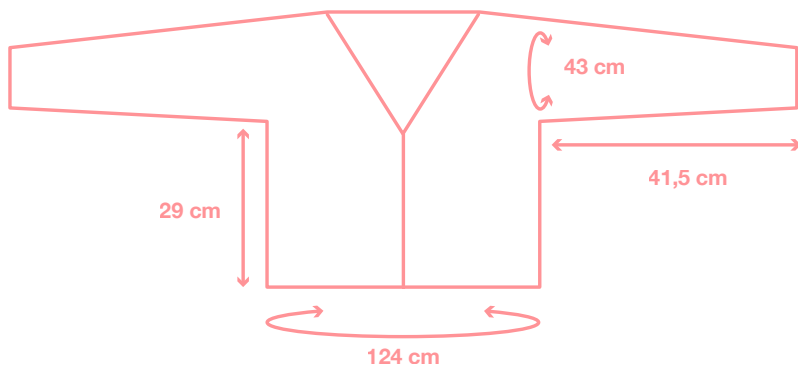

## YARN

9 balls of **AURORA** from Rosários 4, in colour 07 (25g/210m).

## GAUGE

18 sts and 28 rows - 10x10 cm in stockinette stitch with 4,5 mm needle, washed and blocked (*it's important to wash and block your swatch in order to get the correct gauge*).

## NEEDLES

3,5 mm and 4,5 mm circular needles (*if necessary, adjust the needle size to match the gauge*).

## NOTIONS

Stitch markers, tapestry needle, waste yarn, 4 buttons.

## SIZE

L.

## FINISHED MEASUREMENTS

124 cm final bust measurements (*refer to schematic for more measurements*); **with approximately 15 cm of positive ease**.

**Note:** the cardigan is knitted with 2 strands of yarn held together.

## INSTRUCTIONS

### NECKLINE

I-cord cast-on:

With waste yarn and smaller needles, cast on 3 sts. Change to working yarn and knit 3 sts. Slip the 3 sts back to left hand needle and **Kfb**, K2; slip 3 sts back to left hand needle (leave 1 st in right hand needle); [**Kfb**, K2; slip 3 sts back to left hand needle] rep until you have a total of 61 sts in the needles. Turn work.

Change to bigger needles and work the **set-up row (WS)**: P5, **pm**, P6, **pm**, P8, **pm**, P8, **pm**, P10, **pm**, P8, **pm**, P8, **pm**, P6, **pm**, P2, unravel the waste yarn cast-on and purl the 3 released sts. [64 sts]

Work increases for shoulders, back and neckline with i-cord edgings:

**Row 1 (RS)**: K3, **Kfb** x 2, slm, K6, slm, **Kfb**, [K to 1 st before marker, **Kfb**, slm] x 2, [K to marker, slm, **Kfb**] x 2, K to 1 st before marker, **Kfb**, slm, K6, slm, **Kfb** x 2, K3.

**Row 2**: sl3 wyif, P to 1 st before marker, **Pfb**, slm, P6, slm, **Pfb**, [P to marker, slm] x 4, P to 1 st before marker, **Pfb**, slm, P6, slm, **Pfb**, P to 3 sts from end, sl3 wyif.

**Row 3**: K3, **Kfb**, K to 1 st before marker, **Kfb**, slm, K6, slm, **Kfb**, [K to marker, **Kfb**, slm] x 2, [K to marker, slm, **Kfb**] x 2, K to 1 st before marker, **Kfb**, slm, K6, slm, **Kfb**, K to 4 sts from end, **Kfb**, K3.

**Row 4**: sl3 wyif, P to 1 st before marker, **Pfb**, slm, P6, slm, **Pfb**, [P to marker, slm] x 4, P to 1 st before marker, **Pfb**, slm, P6, slm, **Pfb**, P to 3 sts from end, sl3 wyif.

Repeat rows 3 and 4, 7 more times. [32 sts in fronts; 6 sts in shoulders; 114 sts in back]

Rearrange markers and work neckline and sleeve increases:

**Row 1 (RS)**: K3, **Kfb**, K to 2 sts before marker, **pm**, **Kfb** x 2, remove marker, **Kfb** x 6, remove marker, **Kfb** x 2, **pm**, K to 2 sts before marker (remove markers from the back), **pm**, **Kfb** x 2, remove marker, **Kfb** x 6, remove marker, **Kfb** x 2, **pm**, K to 4 sts from end, **Kfb**, K3. [31 sts in fronts; 20 sts in sleeves; 110 sts in back]

**Row 2 (WS)**: sl3 wyif, P to 3 sts from end, sl3 wyif.

**Row 3**: K3, **Kfb**, [K to marker, slm, **Kfb**, K to 1 st before marker, **Kfb**, slm] x 2, K to 4 sts from end, **Kfb**, K3.

**Row 4**: sl3 wyif, P to 3 sts from end, sl3 wyif.

Repeat rows 3 and 4, 25 more times. [57 sts in fronts; 72 sts in sleeves]

Continue working sleeve increase and work the first buttonhole:

**Row 1**: [K to marker, slm, **Kfb**, K to 1 st before marker, **Kfb**, slm] x 2, K to 5 sts from end, **K2tog, yo**, K3.

**Row 2**: sl3 wyif, P to 3 sts from end, sl3 wyif.

**Row 3**: [K to marker, slm, **Kfb**, K to 1 st before marker, **Kfb**, slm] x 2, K to end.

**Row 4**: sl3 wyif, P to 3 sts from end, sl3 wyif.

Repeat rows 3 and 4, once. [78 sts in sleeves]

**SEPARATE SLEEVES (RS)**: K to marker, remove marker, slip next 78 sts to waste yarn and leave on hold, slm, K to marker, remove marker, slip next 78 sts to waste yarn and leave on hold, slm, K to end. [57 sts in fronts; 110 sts in back; 224 sts for body]

**Work WS row**: sl3 wyif, P to 3 sts from end, sl3 wyif.



**BODY**

Work the body in stockinette stitch with i-cord edgings:

**Row 1 (RS):** K to end.

**Row 2 (WS):** sl3 wyif, P to 3 sts from end, sl3 wyif.

Continue working in established pattern and, at the same time, work the second buttonhole on row 21 of the body and the third buttonhole on row 47.

**Buttonhole row (RS):** K3, K to 5 sts from end, **K2tog, yo**, K3.

Continue working in established pattern until you complete a total of 64 rows on the body. The garment should measure approximately 23 cm height from the armhole. Change to smaller needle and work the bottom hem decreases:

**Row 1, decreases (RS):** K3, K9, **K2tog**, [K7, **K2tog**] x 22, K to end. [201 sts]

Work hem in 1x1 ribbing:

**Row 2 (WS):** sl3 wyif, [K1, P1] rep to 4 sts from end, K1, sl3 wyif.

**Row 3:** K3, [P1, K1] rep to 4 sts from end, P1, K3.

**Row 4:** sl3 wyif, [K1, P1] rep to 4 sts from end, K1, sl3 wyif.

Repeat rows 3 and 4, 4 more times.

Work the last buttonhole:

**Row 13:** K3, [P1, K1] rep to 5 sts from end, **K2tog, yo**, K3.

**Row 14:** sl3 wyif, [K1, P1] rep to 4 sts from end, K1, sl3 wyif.

**Row 15:** K3, [P1, K1] rep to 4 sts from end, P1, K3.

**Row 16:** sl3 wyif, [K1, P1] rep to 4 sts from end, K1, sl3 wyif.

Repeat rows 15 and 16 once. With bigger needles, bind off all sts in ribbing pattern.

**SLEEVES**

Slip the 78 sts on hold for the sleeve, back to working needles. Join to work in the round and place the beginning of round marker. Knit all rows until the sleeve measures 37 cm from the armhole.

Work a decrease rnd: [K1, **K2tog**] x 26. [52 sts]

Change to smaller needles and work the hem in 1x1 ribbing: [K1, P1] rep to end. Work 12 rnds in ribbing pattern. With bigger needles, bind off all sts in ribbing pattern.

**ABBREVIATIONS**

**K:** knit

**P:** purl

**cm:** centimeters

**st/sts:** stitch/stitches

**rep:** repeat

**rnd/rnds:** round/rounds

**RS:** right side

**WS:** wrong side

**pm:** place marker

**slm:** slip marker

**Kfb:** Knit front and back (*knit 1 stitch but don't drop it of left hand needle; knit the same stitch again through back loop and drop it off the needle*)

**Pfb:** purl front and back (*purl 1 stitch but don't drop it of left hand needle; purl the same stitch again through back loop and drop it off the needle*)

**sl3 wyif:** slip 3 sts purlwise and with the yarn in front of the work

**yo:** yarn over

**K2tog:** knit 2 stitches together

**Stockinette stitch:** knit all right side rows and purl all wrong side rows (*in the round: knit all rounds*)

**SUPPORT VIDEOS**

[I-cord cast-on](#)

[I-cord edges](#)

[Kfb and Pfb increases](#)

[K2tog decrease](#)



**AURORA Colour 07**  
(70% mohair kid, 30% silk)



PURE NEW WOOL



ISO 9001

40  
YEARS